

Investigative Architecture

The Conceptual Diagram

The Open Group
23rd Enterprise Architecture Practitioners Conference
July 22th 2009

Ben Sommer, *Senior Consultant*, Systems Flow, Inc.

Dan Hughes, *Principal Consultant*, Systems Flow, Inc

James Hosey, *Senior Consultant*, Systems Flow, Inc.



Abstract

Formal UML-based notation provides a powerful tool for architecture design and communication. There is also a compelling need for crisp, clear, and marketing-friendly architecture diagrams for use in executive presentations. The creation of polished, clear and well-scoped renditions of an architecture can be more art than science, so we propose a diagram that balances the appropriate level of accuracy with enough flexibility for targeted marketing. This same view also provides a clear "at a glance" representation of an architecture, setting the scope for more detailed, formal views.

Presentation Overview

- The Challenge
- The Solution
- The Tool
- Investigative Architecture Review
 - Diagrams
 - Approach
 - Inputs
- Rubrics
- Case Study
- References

The Challenge

- Mission of enterprise architecture mission is to align technology design with business interests

Intended Audience	Key Modeling Challenges
Technical Stakeholder	Proper scope and accuracy
Business Executive	Marketing & selling solution

The Solution

- A formal conceptual diagram approach that results in a work product that is:
 - A marketing view flexible (and pretty) enough to catch attention in the board room or the sales pitch
 - Formal enough to guide an architect to the right design
 - Lightweight enough to quickly draft as a way to introduce stakeholders to the design
 - Refined enough to serve as a foundation for moving forward (can map to UML diagrams)

Investigative Architecture Core Diagrams

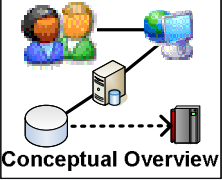
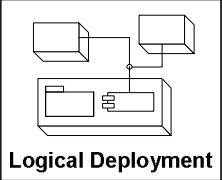
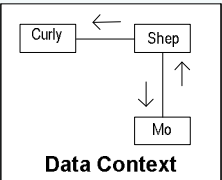
Diagram	Scope	Notation
 <p>Conceptual Overview</p>	PowerPoint View	Icon-based w/guidelines
 <p>Logical Deployment</p>	System View	UML Component Diagram
 <p>Data Context</p>	Data View	UML Collaboration Diagram

You are here



See [Leveraging UML as a Standard Notation for Enterprise Architecture](#) and [Investigative Architecture – Making Sense of your Enterprise](#) for additional information.

Investigative Architecture Process

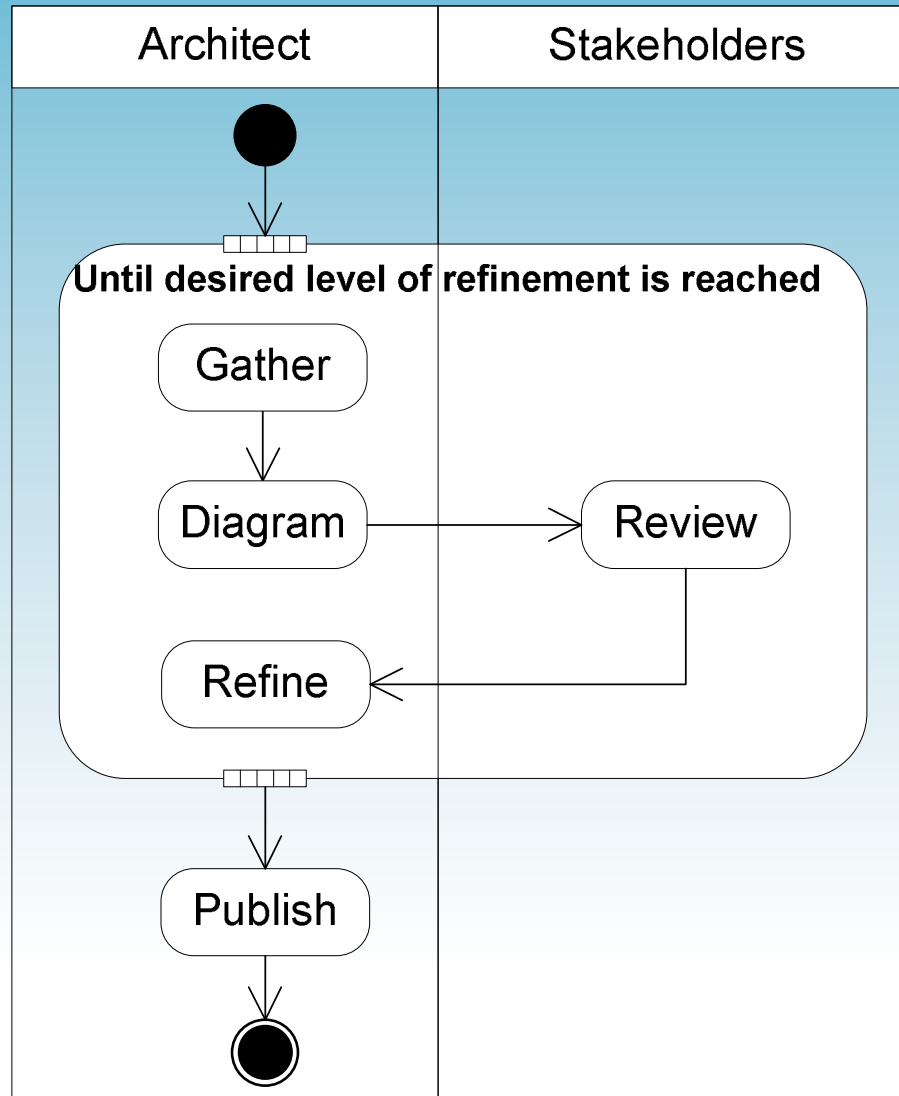

Investigative Architecture Inputs

Information Source	What to Expect	Target Diagram
Vendor	Product Documentation	Logical Deployment
<i>Support Engineer</i>	<i>Operations Manuals</i>	<i>All</i>
Server Engineer	Server Documentation	Logical Deployment
DB Administrator	Database Information	Logical Deployment, Data Context
<i>Business Line</i>	<i>Requirements Artifacts</i>	<i>Conceptual Overview, Data Context</i>
Network Engineer	Network Topography	Logical Deployment
<i>Company Intranet</i>	<i>Links to above information</i>	<i>All</i>
<i>EA Repository</i>	<i>As-is visual models</i>	<i>All</i>
<i>Google, Wikipedia, etc.</i>	<i>Stray pieces of the puzzle</i>	<i>All</i>
CMD.EXE (or csh)	Network information	Logical Deployment

Conceptual Diagram Quick Start

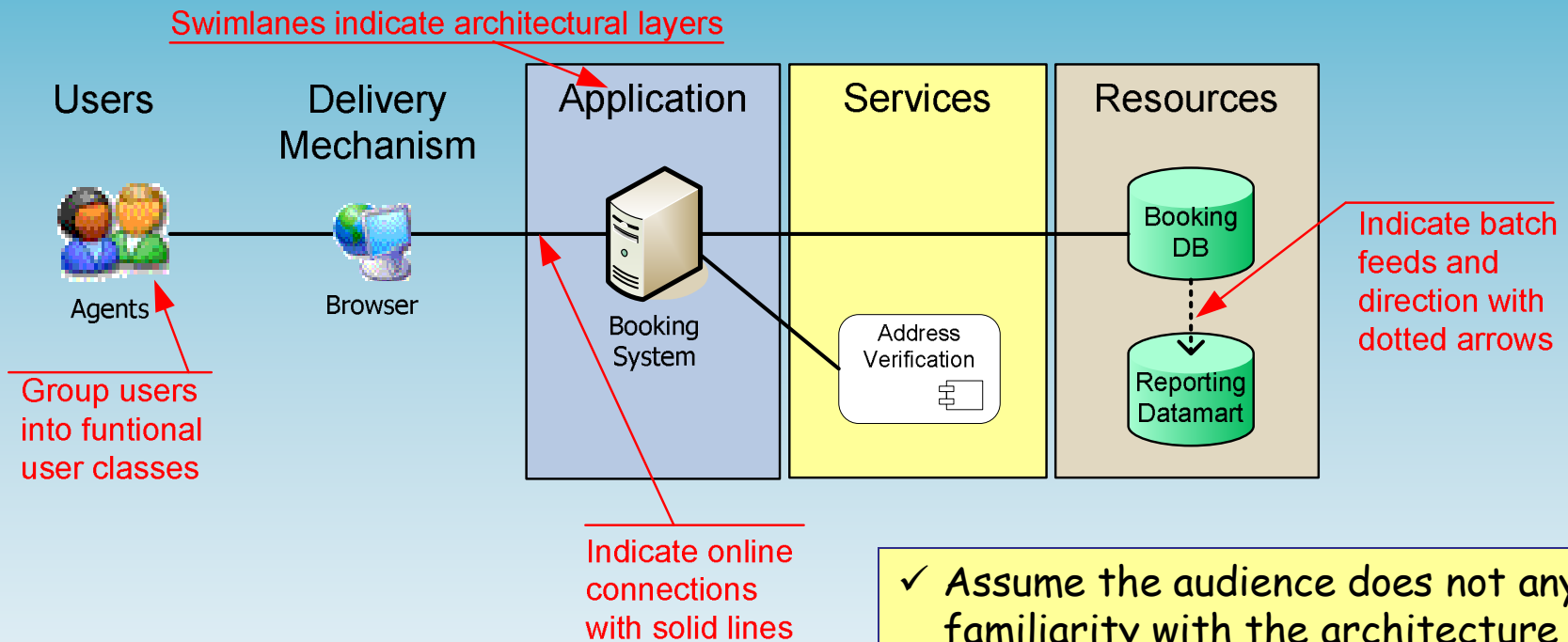

- Left to right depiction of user driven architecture
- Uses standard set of icons
- Designed to fit on one presentation slide

- ✓ Assume the audience does not have any familiarity with the architecture
- ✓ Keep the focus high level and conceptual
- ✓ Do not get distracted by inaccurate details - target "big picture" accuracy
- ✓ Target the diagram to your need
- ✓ Rescope to multiple diagrams to fit

Conceptual Diagram Guidelines

- Assume the audience does not have any familiarity with the architecture
- Keep the focus high level and conceptual
- Do not get distracted by inaccurate details
 - Target “big picture” accuracy
- Target the diagram to your need

Investigative Architecture Case Study

The Company	<i>Massive Insurer, Inc.</i>
The Vendor	<i>EzeDoesIT, Inc.</i>
The Product	<i>EzeWorkflow</i>
The Project	In disarray
The Task	Produce a Conceptual Diagram of the target solution

Input #1 – Email from Business Line

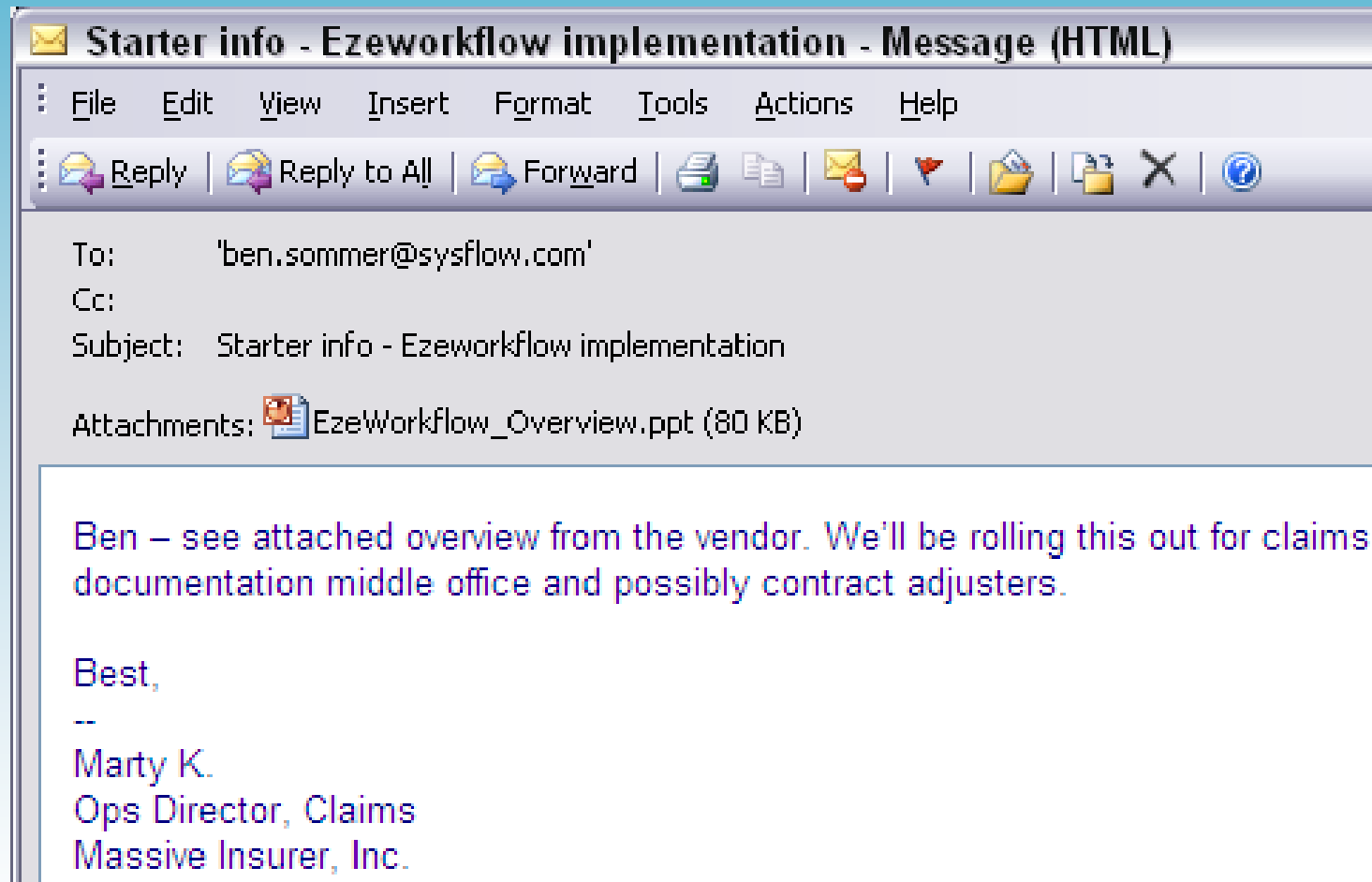

Case Study (continued)

Stub Users

Users

Delivery
Mechanism

Application

Services

Resources

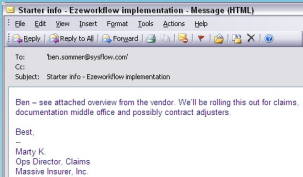

"...possibly contract adjusters"



Adjusters

"..rolling this out for claims"



Claims Agents

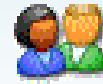

Documentation Specialists

"documentation middle office"

**Case Study
(continued)**

Input #2 – Vendor “Marketecture”

EzeWorkflow – Overall Approach

The proposed solution provides the platform for *Massive Insurer, Inc.* to transform its claims business, providing straight through processing from submission to closure.

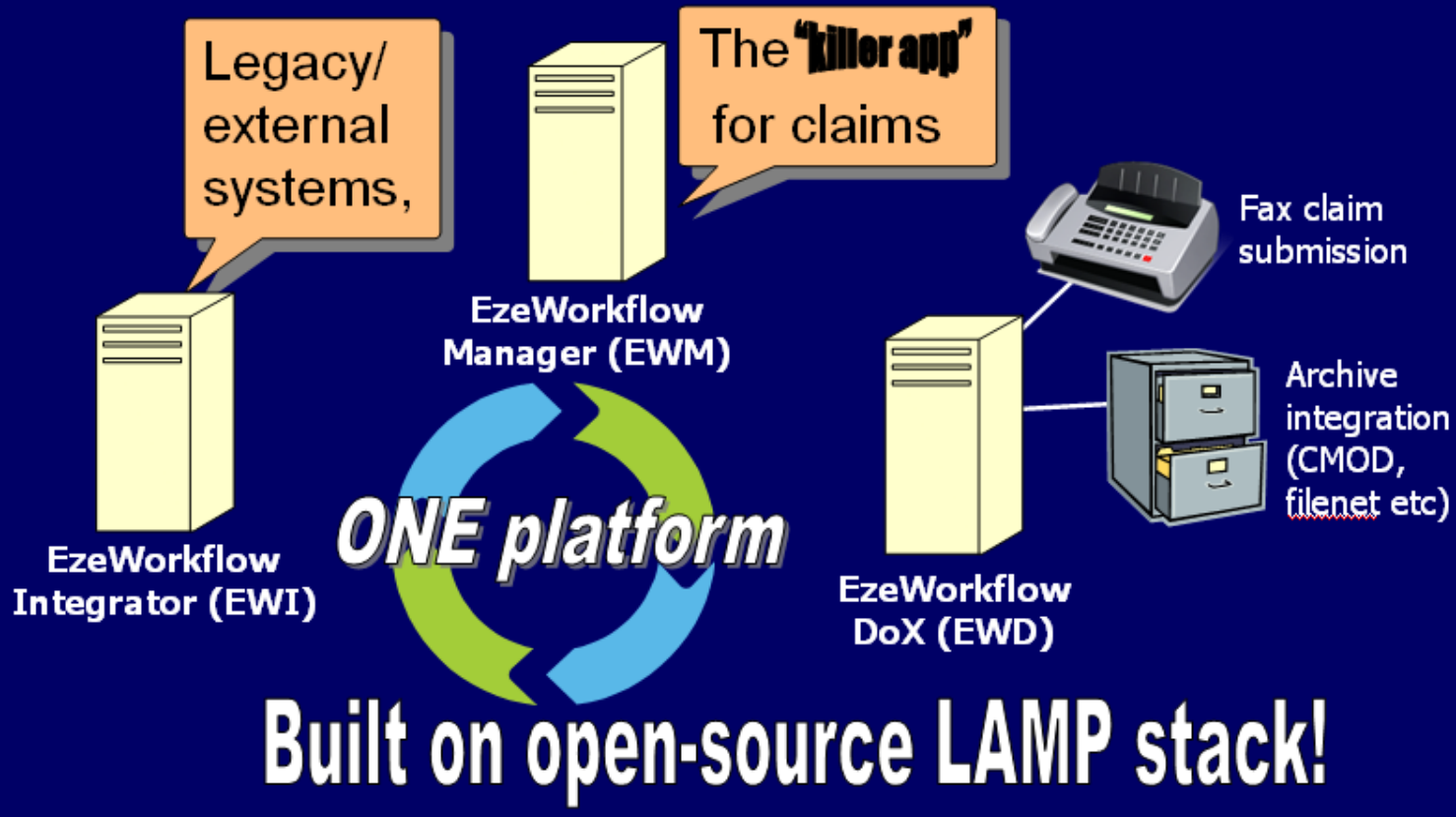

Case Study
(continued)

Application & Legacy Systems

Users

Delivery
Mechanism

Application

Services

Resources

**EzeWorkflow Integrator...
Legacy...systems**

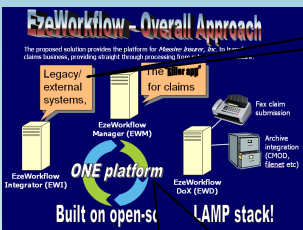
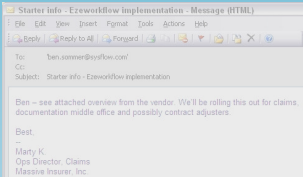

Adjusters

ONE platform

*"ONE platform..." – for
now black-box EWM,
EWI & EWD*



EzeWorkflow

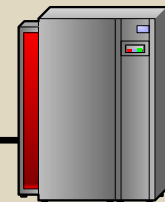

Customer/policy
systems

**Systems of record
on Mainframe**



Claims Agents



Documentation
Specialists

**Case Study
(continued)**

Input #3 – Google Sleuthing



Good old Wikipedia...

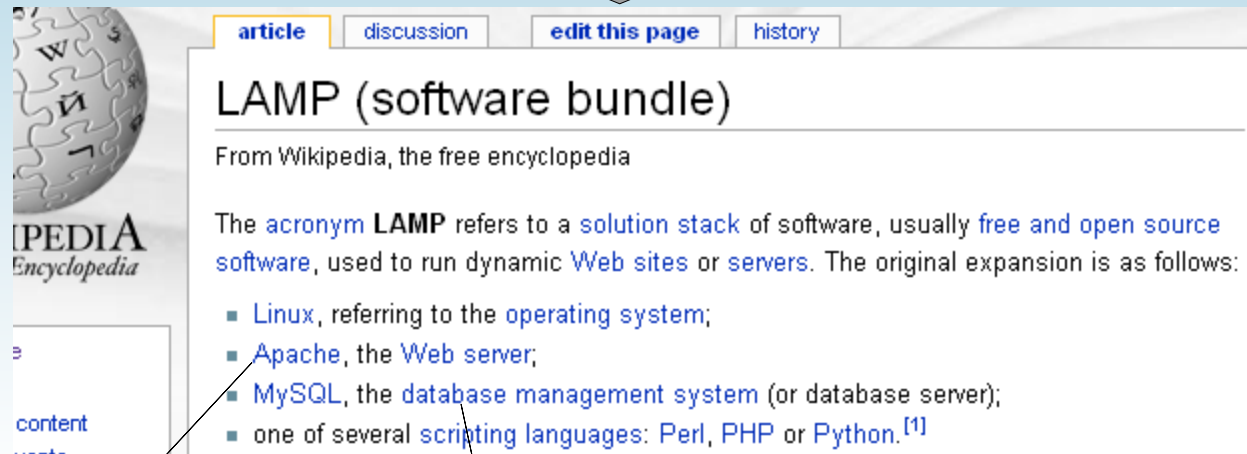
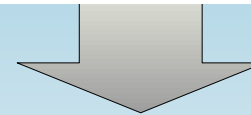

"Apache Web Server"...smells like a web app

And a database

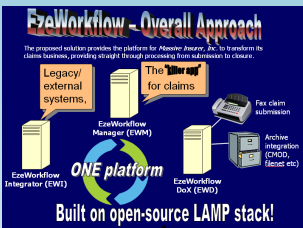
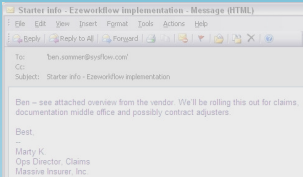

Built on open-source LAMP stack!

Case Study
(continued)

App – Front-end & Back-end

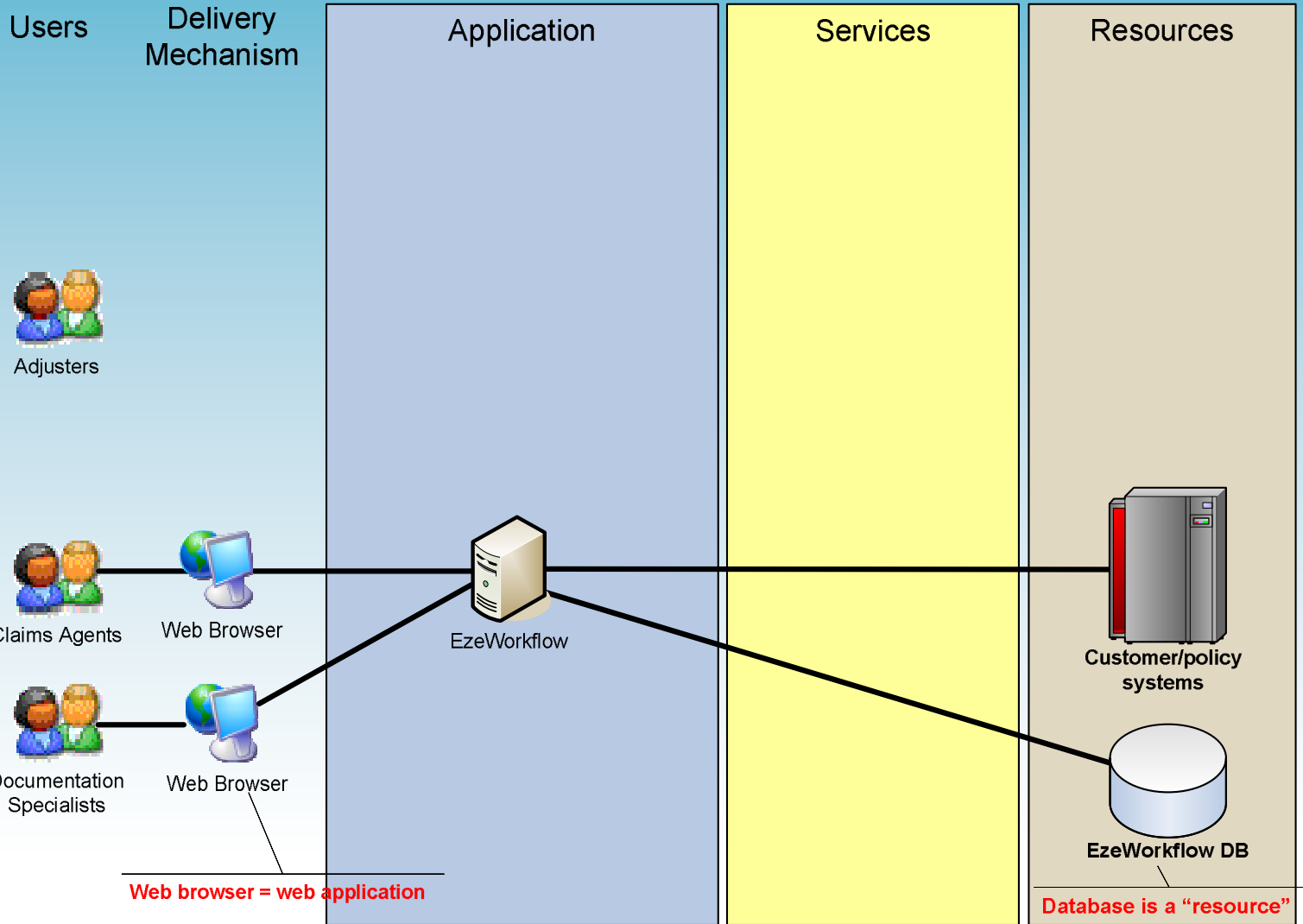

**Case Study
(continued)**

The top screenshot shows an email titled "Starter info - EzeWorkflow Implementation - Message (HTML)" with a subject line "Starter info - EzeWorkflow implementation" and a body mentioning "Ben - see attached overview from the vendor. We'll be rolling this out for claims, documentation middle office and possibly contract adjusters." The sender is listed as "Marty K, Ops Director, Claims, Massive Insurer, Inc."

The bottom screenshot is a presentation slide titled "EzeWorkflow - Overall Approach". It features a diagram showing "Legacy/external systems" and "The 'layer' for claims" feeding into "EzeWorkflow Manager (EWM)", which then connects to "The claim information" and "Archive integration (CHDO, legacy etc)". Below this, it lists "EzeWorkflow Integrator (EWI)" and "Distribution box (EWD)". A central circle contains the text "ONE platform". At the bottom, it states "Built on open-source LAMP stack!".

The bottom screenshot is a Wikipedia article snippet titled "LAMP (software bundle)" with the text: "From Wikipedia, the free encyclopedia. The acronym **LAMP** refers to a solution stack of software, usually free and open source software, used to run dynamic Web sites or servers. The original expansion is as follows:

- Linux, referring to the operating system;
- Apache, the Web server;
- MySQL, the database management system (or database server);
- one of several scripting languages: Perl, PHP or Python.^[1]

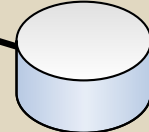
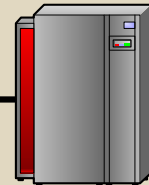
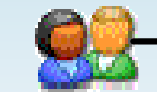

"EzeWorkflow Dox™"

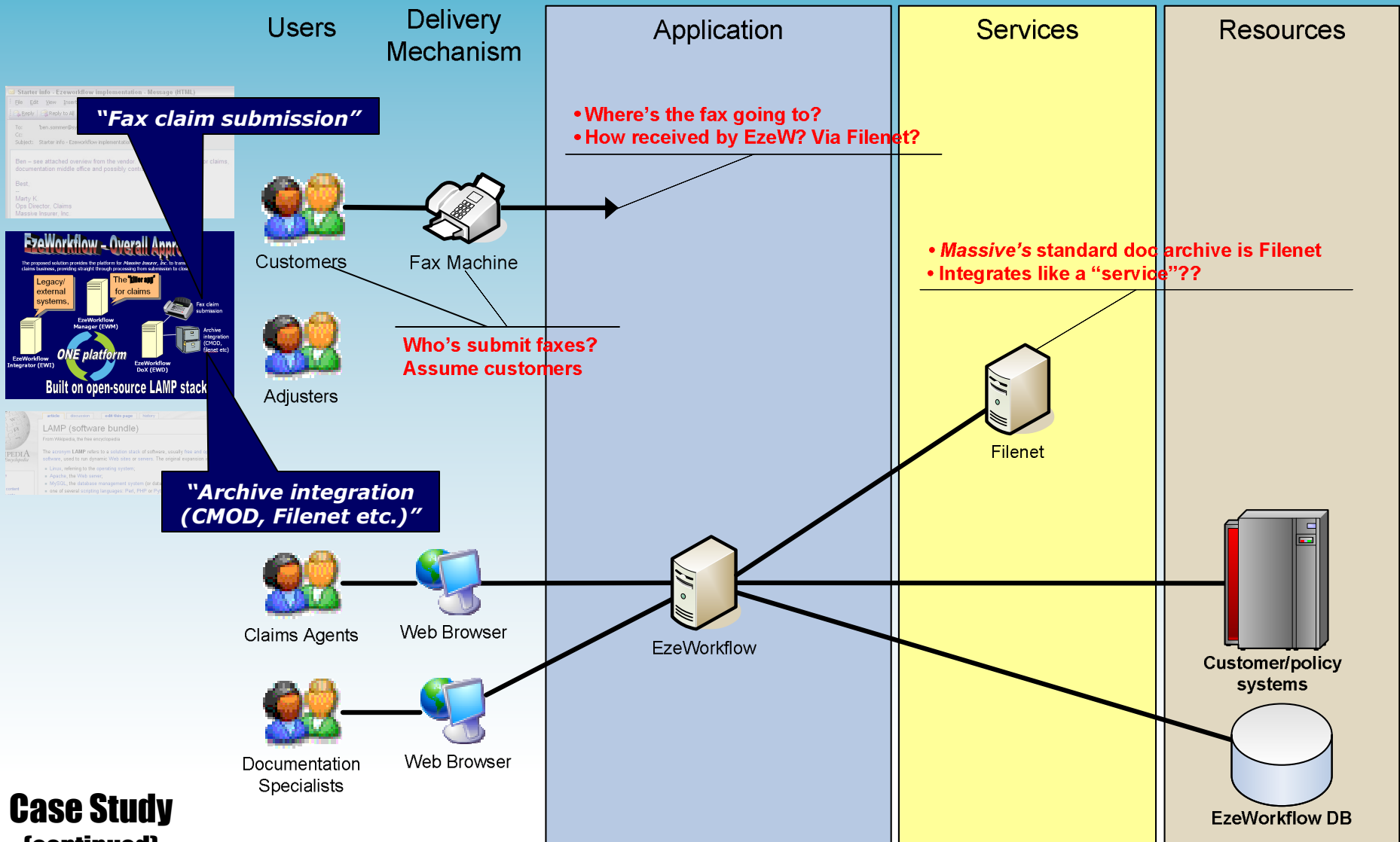

**Case Study
(continued)**

Fax & Archive?

Input #4 – Intranet Sleuthing

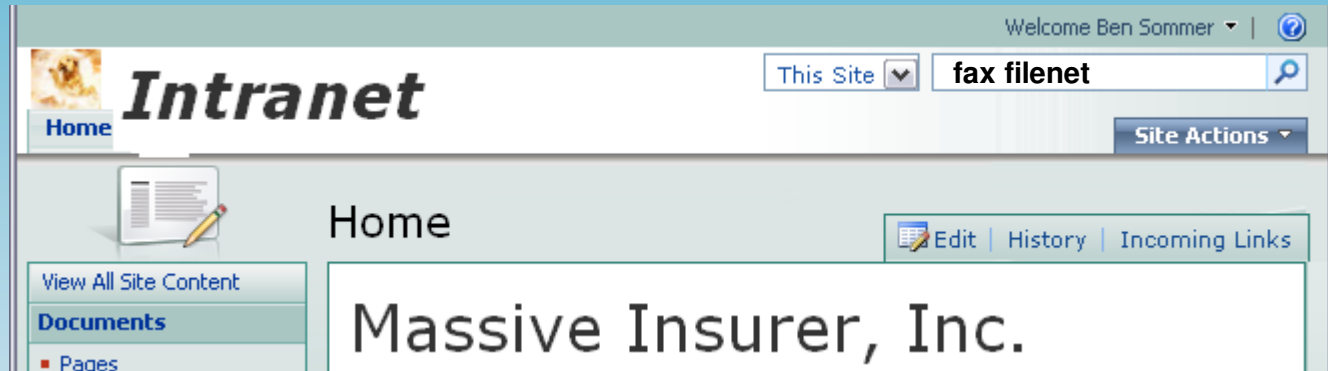
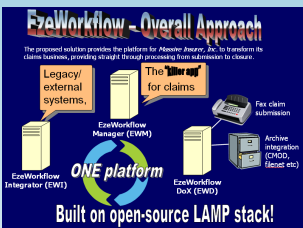
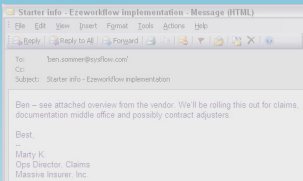

Internal documents insinuate that RightFax is standard fax integration app. Filenet + RightFax – Bingo!

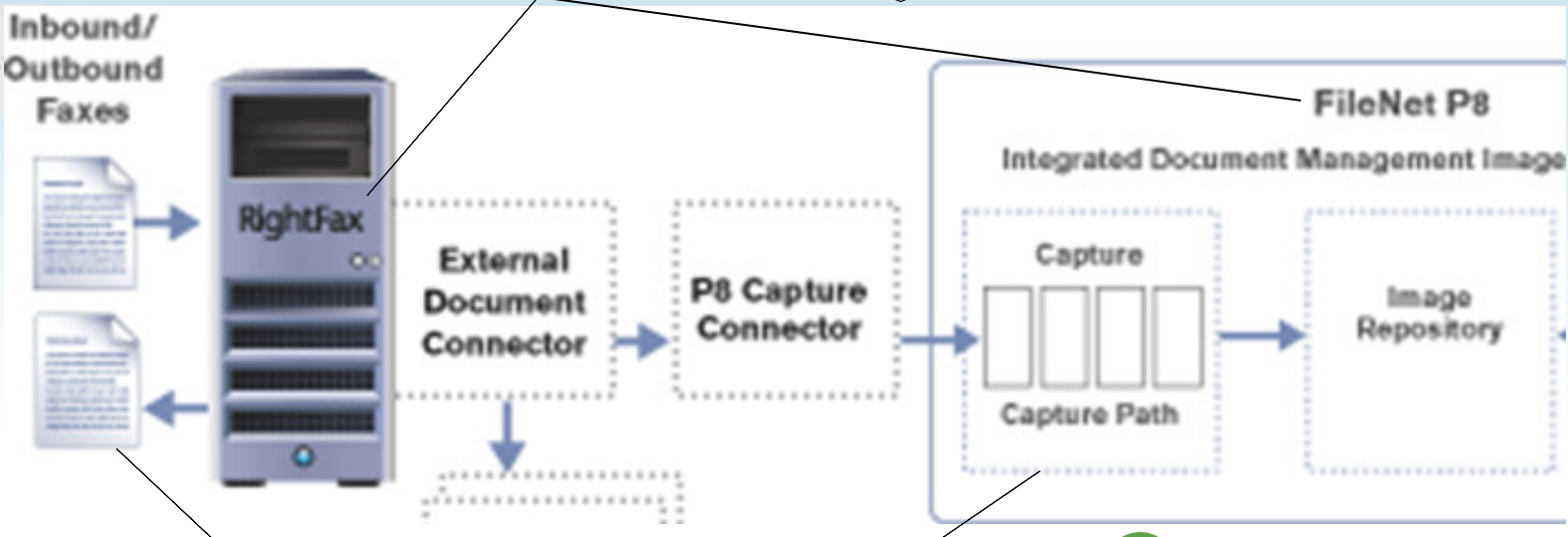
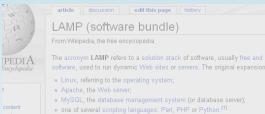

Case Study (continued)

Faxes coming in...

...capture & archive going out



“EzeWorkflow Dox™” (cont’d)

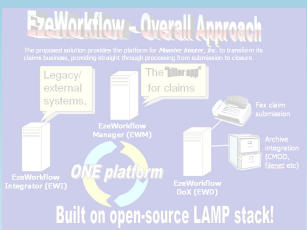
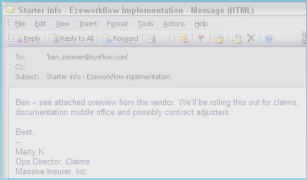
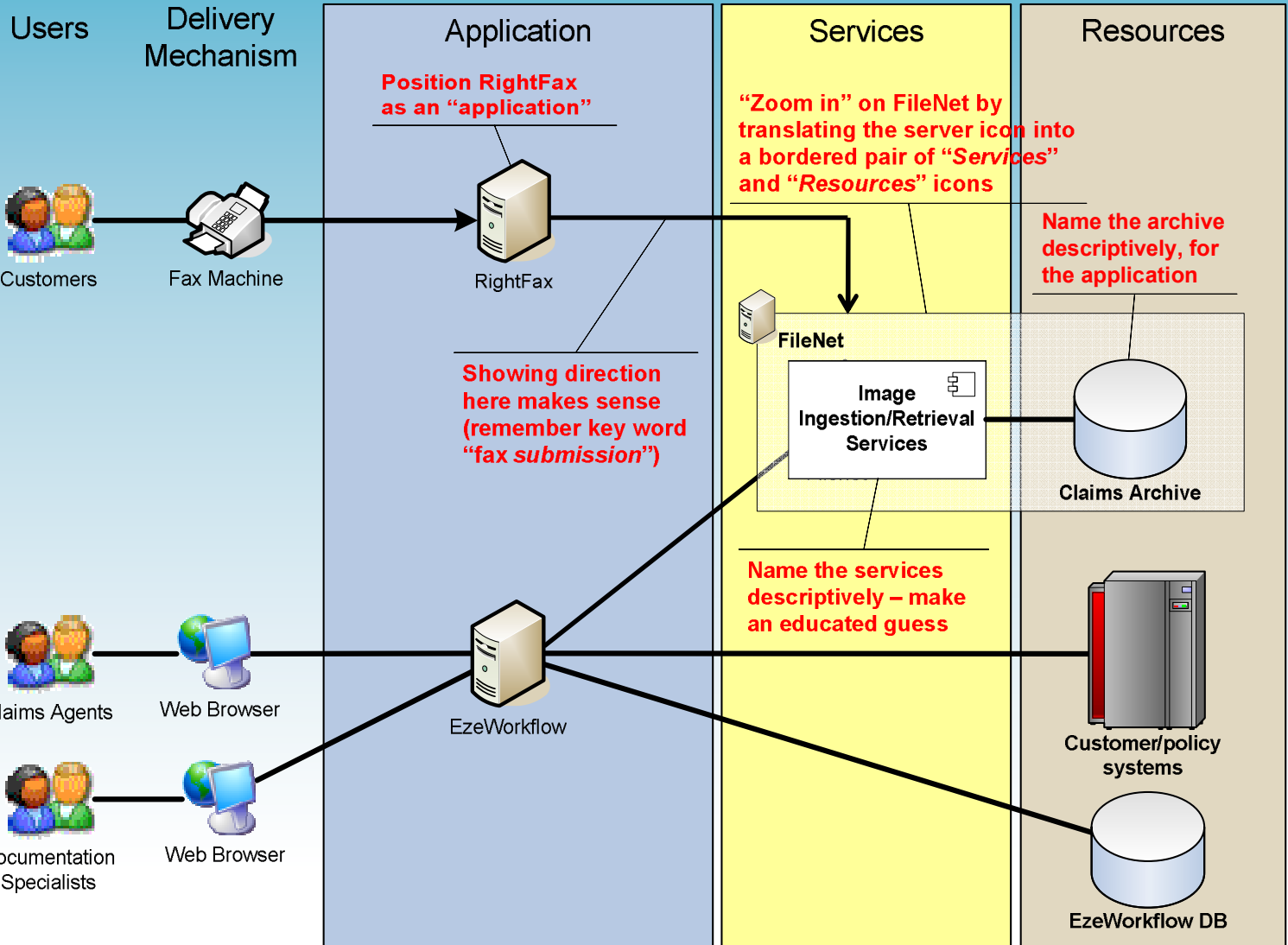

LAMP (software bundle)
 From Wikipedia, the free encyclopedia
 The acronym LAMP refers to a solution stack of software, usually free and open source software, used to run dynamic Web sites or servers. The original expansion is as follows:
 • Linux, referring to the operating system;
 • Apache, the Web server;
 • MySQL, the database management system (or database server);
 • one of several scripting languages: Perl, PHP or Python.^[1]

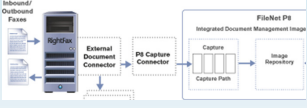

**Case Study
(continued)**

Model "Contract Adjusters"

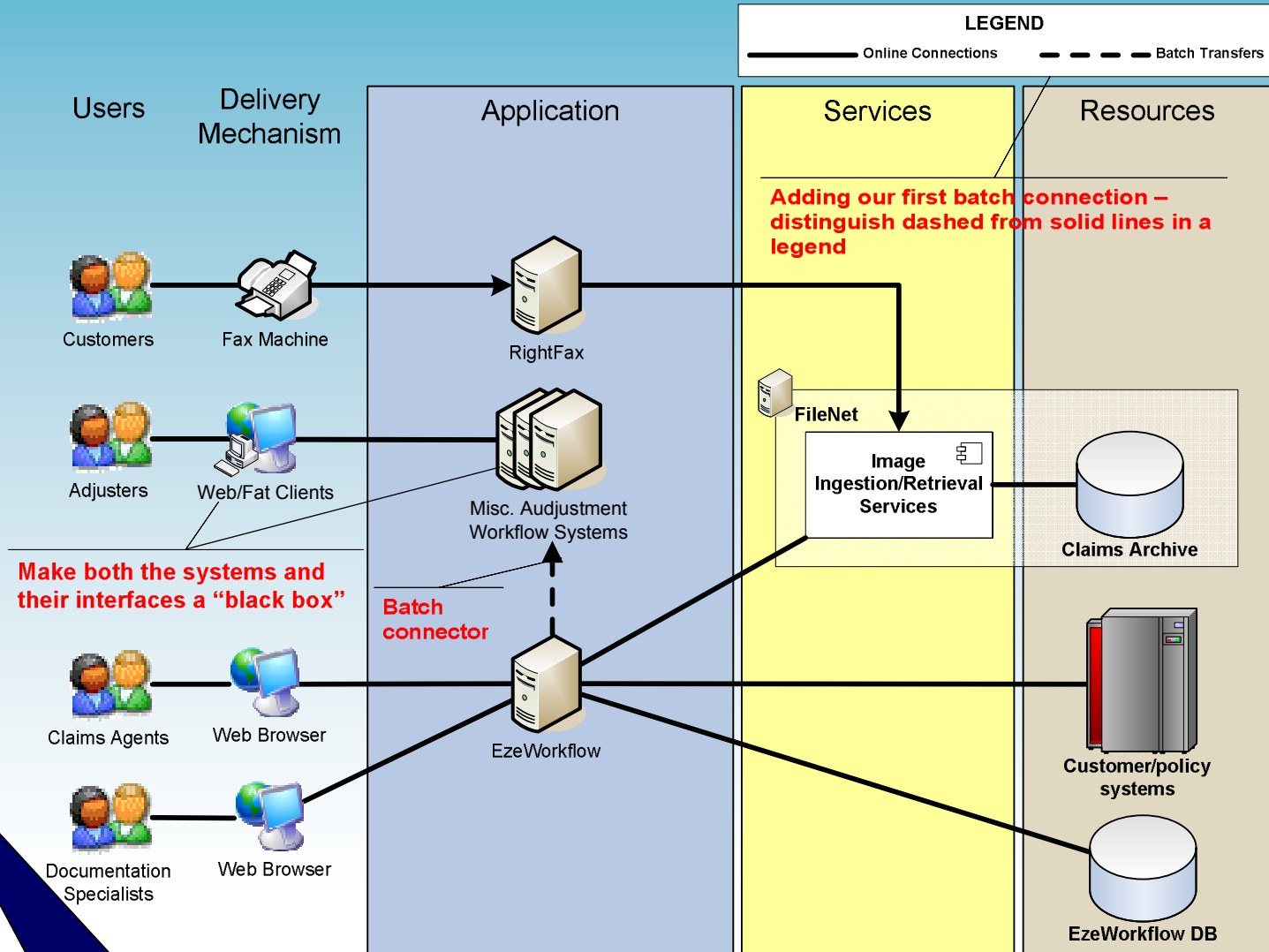
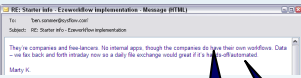
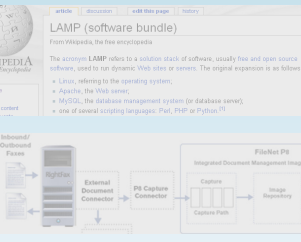
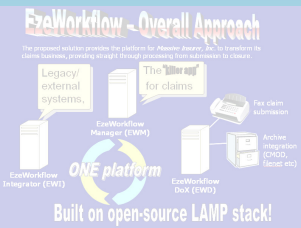
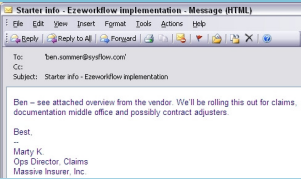

Make both the systems and their interfaces a "black box"

Batch connector

"...daily file exchange..."

"...have their own workflows..."

Case Study (continued)



Tidy Up

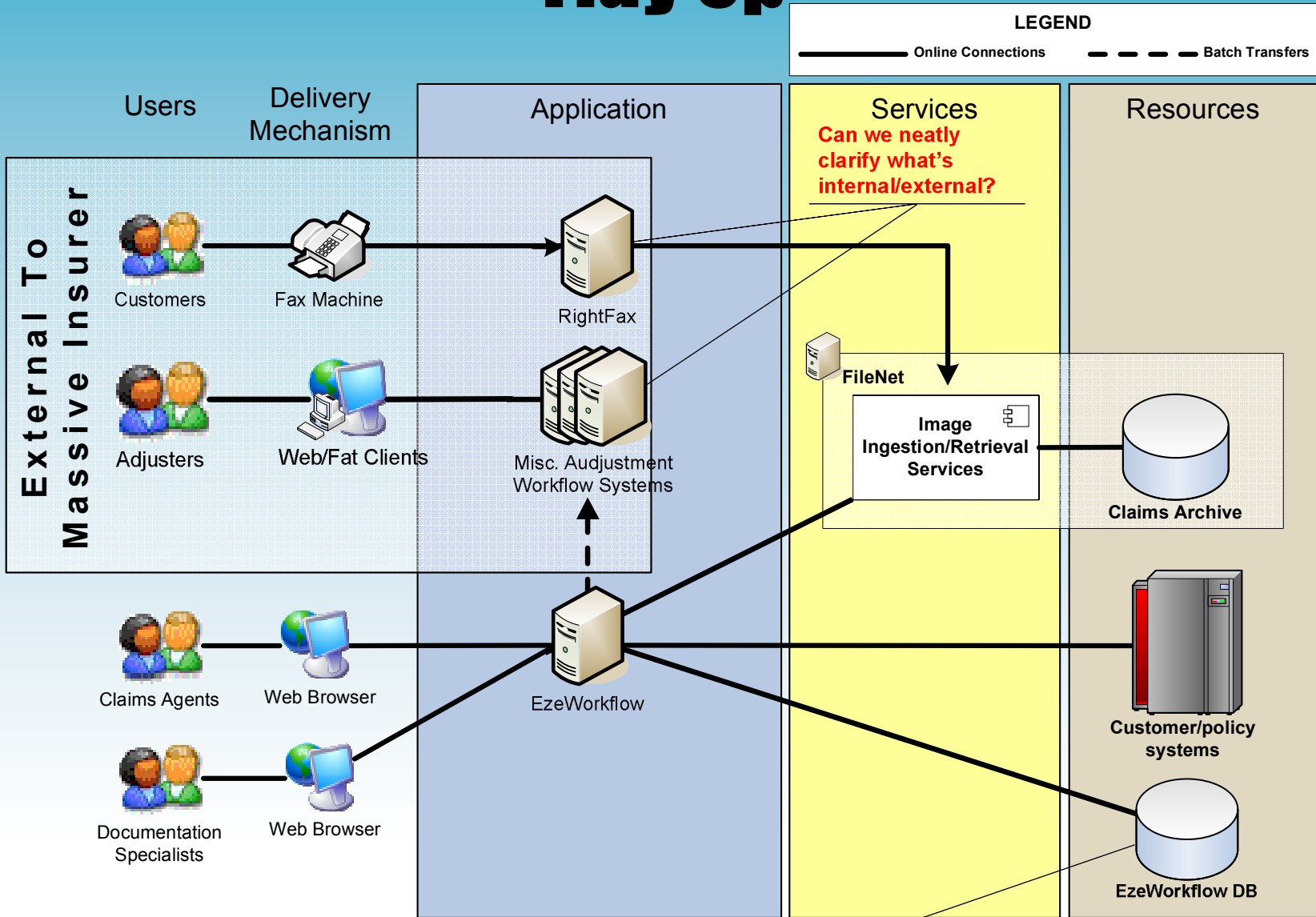

**Case Study
(continued)**

Diagram is getting noisy –
is the DB adding anything?

Final Product

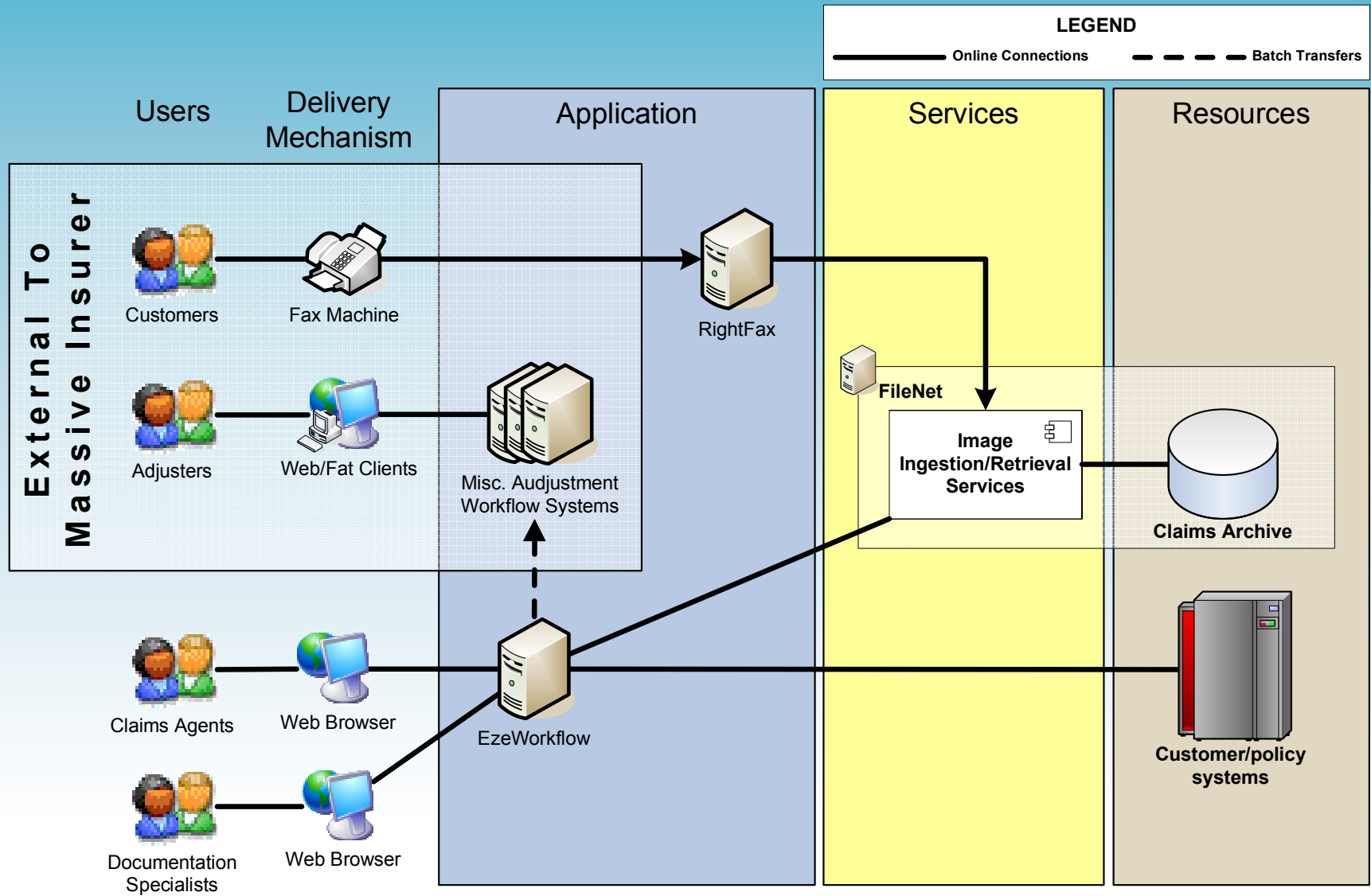

References

- [Leveraging UML as a Standard Notation for Enterprise Architecture](#)
- [Other Systems Flow Whitepapers](#)

QUESTIONS?

Ben Sommer (ben.sommer@sysflow.com) is a senior consultant with Systems Flow, Inc, www.sysflow.com, where he helps organizations dramatically improve their competitive advantage through the practical, effective application of best practices in enterprise architecture and software development. Ben is currently consulting at Citizens Bank, providing architectural leadership for strategic IT projects. His career has spanned network engineering, systems administration, and software development - running the gamut from tools to automate network and systems tasks, to web-based CRM applications, to Identity Management and Provisioning systems, to real-time music synthesis applications. His industry experience includes education, education finance, interactive marketing and banking. Ben is a trained composer and musician.

Dan Hughes (daniel.hughes@sysflow.com) is a principal consultant with Systems Flow, Inc. He is currently engagement lead at Citizens Bank where he guided the launch of the enterprise architecture practice and is now the lead architect for Citizens Bank's Basel II implementation. Dan has 16 years of software engineering experience spanning a broad range of technologies and techniques. Startup to enterprise, he has launched, managed, and executed all aspects of both product and enterprise life cycle for clients in industries ranging from industrial automation to banking and insurance. He maintains a blog on software engineering at xengineering.com. He holds a Bachelor of Science in Computer and Systems Engineering from Rensselaer Polytechnic Institute.

James Hosey (james.hosey@sysflow.com) is a senior consultant with Systems Flow, Inc. is currently engaged at Citizens Bank as an enterprise architect providing strategic architectural guidance and project-specific support across the bank's technology portfolio. Over the course of his 16-year career, Jim has managed and executed all phases of the software life cycle and has delivered a wide variety of technology solutions for both commercial resale and internal use in domains that include banking, insurance, warehousing & distribution, marketing, communications, and management training & development. Having worked with organizations of all sizes, Jim can tailor his approach to the specific driving forces within each type of environment. His experience managing his own consulting practice for ten years has provided him with the entrepreneurial experience necessary to work with stakeholders at all levels to achieve results.